



We increase your machine's
power, economic efficiency and value!

With our tools, your machine will become
multifunctional and more profitable.

Universal Multifunctional Grapple



modularis *drive* 

About us

1991 – First project during college years: Silage cutting machine „OSA“ 1995 - Development and design of handling and gripping tools

1997 – Start of development and production of „Attachments and tools for heavy construction machinery“



2013 – Start of collaboration with the company KGL in developing a new line of hydraulic swivel motors and collaborating in production processes

2013–2017: Development of new Universal Multifunctional Grapples „MODULARIS DRIVE“

2016 – Presentation BAUMA 2016



Why choose Modularis?	1
Multifunctional Grapple for Construction machinery	2
Easily and fast - arms & grip units replacement	3
Innovative Concept	4
The Best Grip with A - synchro hydraulic control system	5
A-Synchro arm (grip unit) movement	6
Universal Modularis Multifunctional Drive unit	7
The Best Grip Grapple	8
Sorting Grapple	12
Alligator Grapple	14
Wood Shear Grapple	18
Timber & Wood & Biomass Grapple	22
Biomass Grapple	25
Bulk material Grapple	27

Why choose **Modularis?**

With our Grapple, your machine will become multifunctional and more profitable.

The construction of the MODULARIS Universal Multifunctional Grapple is designed to completely protect the mechanism and hydraulic system.

Due to the innovative KGL hydraulic Swivel Hydromotor and hydraulic system you can achieve a better grip and rotation as well as more precise control.

Designed for reliable gripping, safe work and quick replacement.

Lower fuel consumption due to the lighter construction and greater power.

Ecologically friendly as it reduces the chance of hydraulic oil spilling into the environment.

Safe purchase, guarantee and try before you buy.

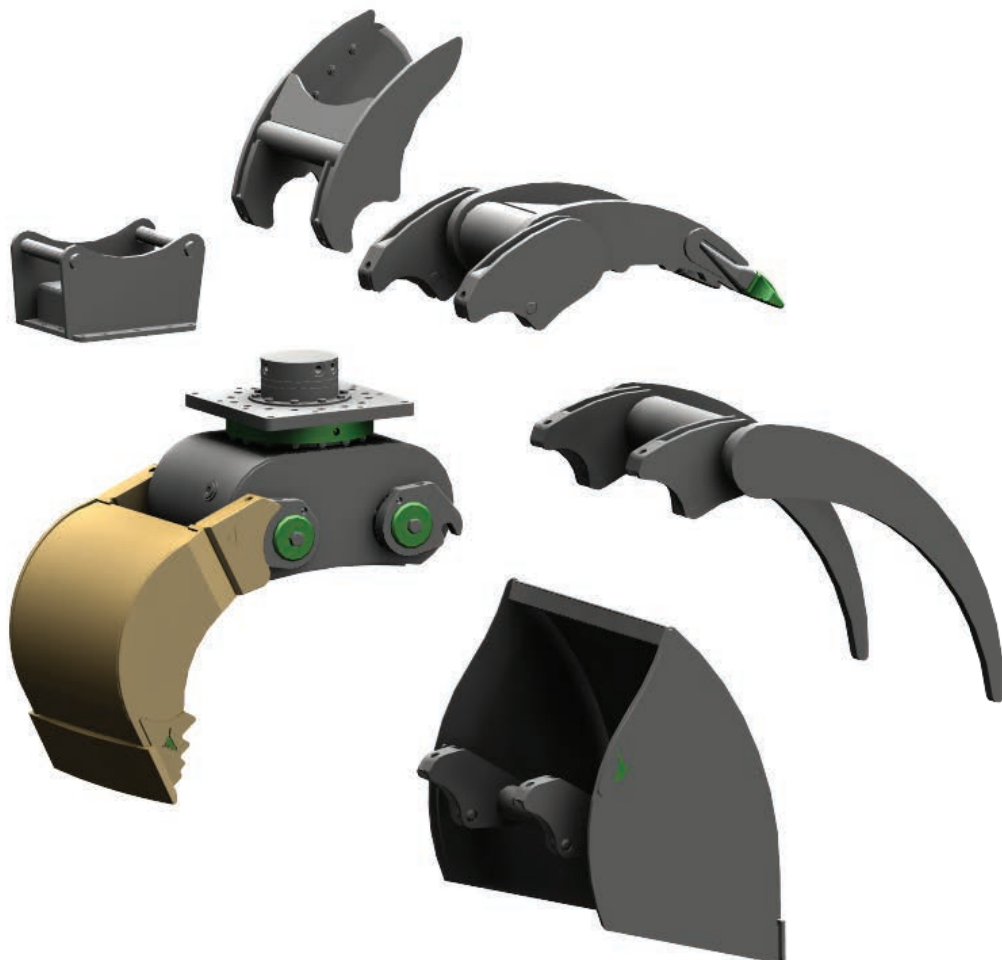

More functions with one tool – Easily and quickly interchangeable arms - grip units

Multifunctional Grapple for Construction machinery



Universal - The Best Grip
Grapple (Demolition & Sorting)



Energy wood &
Biomass Grapple



Sorting Grapple



Aligator Grapple



Bulk material Grapple



Timber & Logs &
Biomass Grapple



Wood Shear Grapple

MAIN BENEFITS

- Easily and quickly interchangeable arms-grip unitsexchange
- Much higher grip power
- Less weight – higher capacity
- Reduced Load centre
- All manipulation / handling functions with one toll for all material
- Totally closed chasis – no damage from outside
- Environmentally friendly product



Modular concept design of the grapple assembly

Easy and fast - **arms & grip units** replacement

Unit replacement by machine operator from the Machine / simply by hand



Replacement by hand, fix with locking screw





Grapple with
the **BEST GRIP**

Reliable & Safe Grip

Designed for reliable gripping, safe work and less energy consumption.

Innovative **Concept**

A – Synchro Control hydraulic system with the best performance. It uses the new innovative principle of operation. Much more gripping power and the most reliable grip.



The BEST GRIP with A - **Synchro hydraulic control system**



The unique Grapple which adapts the gripping force to the load.

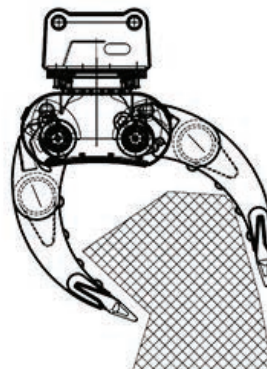
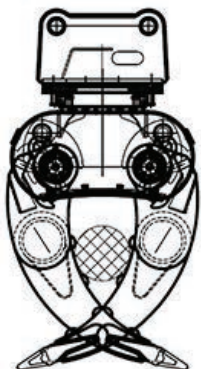
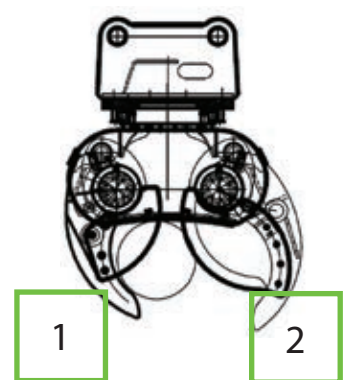
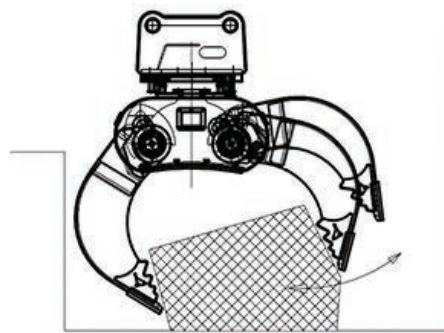
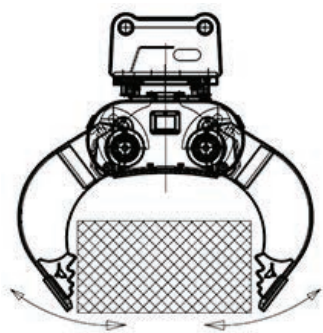

A - Synchro movement

Arms 1&2 - Synchro movement till the load shape (timber, rock, log,..)

Arm 1 - Hold (cut) the load

Arm 2 - continues with movement (gripping, cutting)

A-Synchro arm (grip unit) movement

The only Grapple on the market which has »A – Synchro Grip« synchro & asynchro arm movement – the arms shape & arm movements adapt to the load shape and the functions which the user needs.

Asynchronous movement of the grip arms allows:

- Handling the asymmetric shaped loads in limited positions
- Adjustment of the gripping surfaces of the shape of the load
- Optimal and most reliable grip at the end position of the arms

Advanced approach of the Grapple design **the new Innovative Modularis Drive Unit**

Other concepts

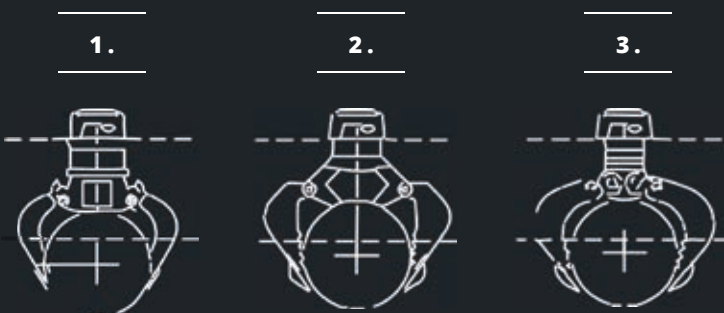

Our concept

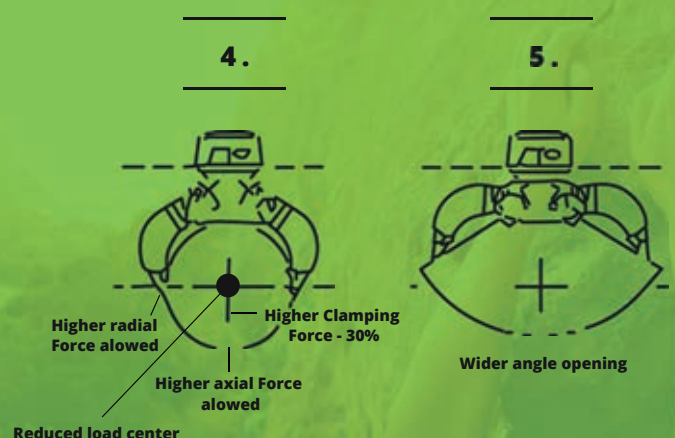

Universal Modularis

Multifunctional Drive unit

The new Universal Multifunctional Drive unit for all applications uses different arms – shells – grip units, for demolition, sorting, handling & Rock handling, Wood Shearing, waste sorting, root pulling & forestry work.

New innovative hydraulic drive concept - model protection & patent pending.

- Extremely robust due to high quality material and new design with totally closed chasis
- Integrated non-return valve guarantees secure retention of loads.
- Including the innovative KGL Swivel motor with 360° endless rotation for precise manipulation
- 30% higher closing force achieved by new Modularis Drive hydraulic system/ 30% less weight due to innovative design
- A – Synchro movement adapts the arm grip to the load shape

Machine op. weight (t/lbs)	Shaft Torque (Nm/ft.lbs)	Rotation Tor. (Nm/ft.lbs)	Flow Rot. (l/min-GPM)	Flow Clamp (l/min-GPM)	Axial L. Cap. (kN)/lbf)	Radial Cap. (kNm /lbf)	Weight (kg/lbs)	Article Code
3 - 5	6 600 - 11 000	8200 6048	1200 885	7 1,85	1200 885	20 5,28	35 7868	166 366 MD 3.0 E
5 - 8	11 000 - 17 600	17800 13129	1500 1106	10 2,64	1500 1106	35 9,25	45 10116	235 518 MD 6.0 E
8 - 12	17 600 - 26 400	23400 17259	1500 1106	15 3,96	1500 1106	45 11,89	63 14163	260 573 MD 9.0 E
10-15	22 000 - 33 000	31600 23307	2000 1475	15 3,96	2000 1475	50 13,21	84 18884	345 761 MD 12.0 E
14- 18	30 800 - 39 600	34900 25741	2500 1844	20 5,28	2500 1844	60 15,85	112 25179	475 1047 MD 16.0 E
17 - 21	37 400 - 46 200	43200 31863	3500 2581	20 5,28	3500 2581	100 26,42	140 31473	700 1543 MD 20.0 E
19 - 25	41 800 - 55 000	55800 41156	4000 2950	35 9,25	4000 2950	120 31,70	175 39342	780 1720 MD 25.0 E
23 - 30	50 600 - 66 000	85000 62693	5000 3688	35 9,25	5000 3688	150 39,63	210 47210	950 2094 MD 30.0 E

Max. Op. pressure MPa (bar / psi) = 35(350) / 5071



Models MD 3.0 - 12.0
 High precision KGL Swivel motor
 High capacity radial bearing significantly increases the payload of the Grapple
 Modularis A – Synchro Hydraulic Drive for the most reliable Grip allows Synchro & Asynchro arms movement



Models MD 16.0 - 30.0
 Rotation with hydromotor and transmission reduction

The Best **Grip Grapple**

(Universal Demolition, Sorting, & Digging & Rock handling)

A-SYNCHRO ARM MOVEMENT

**ENVIROMENTALLY
FRIENDLY**

**SELF TOUCH
SYSTEM**

**COMPLETELY PROTECTED
MECHANISM AND HYDRAULIC
SYSTEM**

**MORE GRIP
POWER**

**LESS WEIGHT - REDUCED LOAD
CENTER - HIGHER CAPACITY**

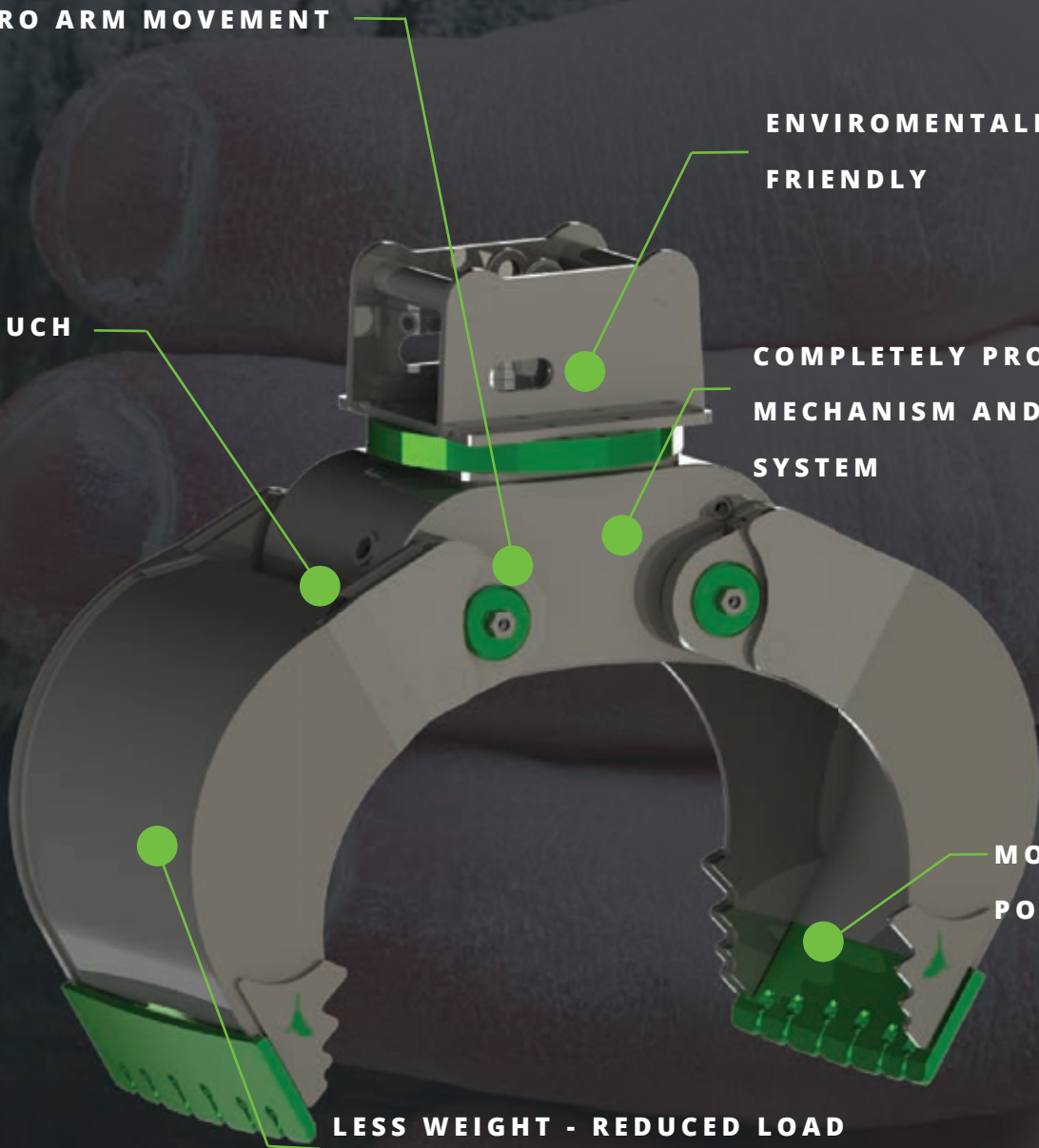



Grapple with
the **BEST GRIP**



Each gripping detail is designed with a purpose – the Best Grip Grapple



Demolition



Rock Handling and Manipulation



Timber & wood handling, Placing wooden piles

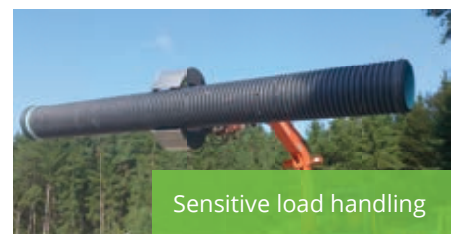
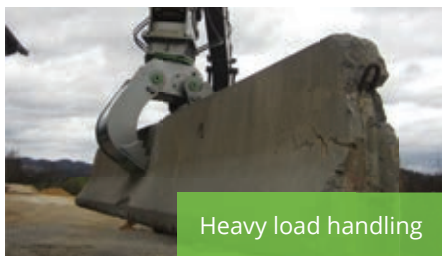

Modularis Multifunctional tool

The new Universal Multifunctional “the best Grip” Grapple for demolition & sorting & Rock Handling for excavators from 3t / 6600 lbs to 30t / 66000 lbs operating weight

- New improved The best grip arm shape - model protection
- The new innovative design - We simply imitated the hHuman hands .
- Extremely robust due to the use of cutting edge material 50HB steel
- Much more higher Grip power achieved by new shape
- The most reliable Grip achieved by A – Synchro arms
- movement adapts to the load shape.

The Best Grip Grapple (Universal / Sorting / Demolition / Digging / Rock handling)

Type	Volume (l/c.y.)	Width B (mm/in)	Max Opening A (mm/in)	Height (mm)	Closing force F (kN/lbs)	Arms Weight (kg / lbs)	Total Grapple weight(kg/lbs)
MD 3.0	70 / 0,09	350 / 13,78	1050 / 41,34	750 / 29,53	16 / 3597	74 / 163	240 / 529
MD 6.0	150 / 0,20	450 / 17,72	1400 / 55,12	880 / 34,65	29 / 6519	130 / 287	365 / 805
MD 9.0	250 / 0,33	550 / 21,65	1650 / 64,96	980 / 38,58	31 / 6969	190 / 419	450 / 992
MD 12.0	300 / 0,39	600 / 23,62	1700 / 66,93	1150 / 45,28	36 / 8093	260 / 573	605 / 1334
MD 16.0	420 / 0,55	650 / 25,59	1750 / 68,90	1370 / 53,94	46 / 10341	300 / 661	775 / 1709
MD 20.0	560 / 0,73	800 / 31,50	2200 / 86,61	1450 / 57,09	55 / 12364	490 / 1080	1190 / 2624
MD 25.0	760 / 0,99	900 / 35,43	2300 / 90,55	1550 / 61,02	75 / 16861	585 / 1290	1365 / 3009
MD 30.0	870 / 1,14	1000 / 39,37	2400 / 94,49	1650 / 64,96	85 / 19109	690 / 1521	1640 / 3616

Grapple weight - without connection plate



Sorting Grapple

A-SYNCHRO ARM MOVEMENT

ENVIROMENTALLY FRIENDLY

SELF TOUCH SYSTEM

COMPLETELY PROTECTED MECHANISM AND HYDRAULIC SYSTEM

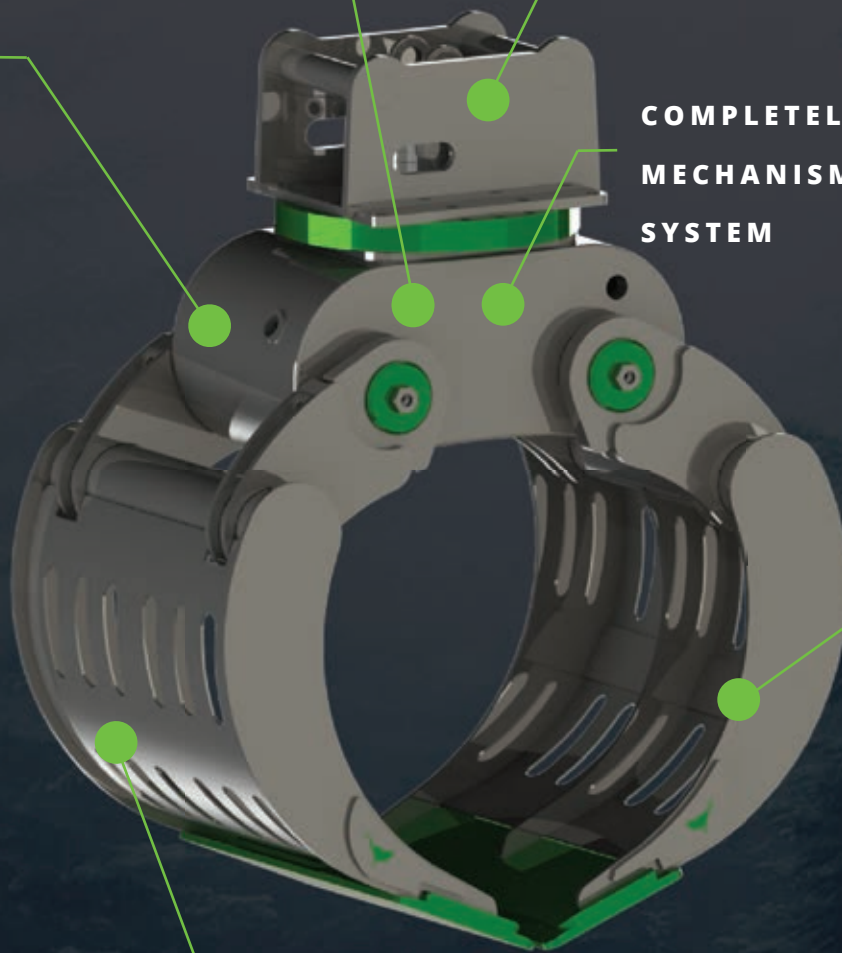

MORE GRIP POWER

LESS WEIGHT - REDUCED LOAD CENTER - HIGHER CAPACITY

Modularis Multifunctional tool - Sorting Grapple

The new Universal Multifunctional "Sorting" Grapple for sorting for excavators from 6t / 13200 lbs to 25t / 55000 lbs operating weight

- Wide range of sorting applications used by most customers.
- Modularis recommends a more useful version "the Best GRIP"
- Extremely robust due to the use of cutting edge material 500 HB steel
- The most reliable Grip achieved by A – Synchro arms movement adapts to the load shape.

Sorting Grapple (Universal / Sorting)

Type	Volume (l/c.y.)	Width B (mm/in)	Max Opening A (mm/in)	Height (mm)	Closing force F (kN/lbs)	Arms Weight (kg / lbs)	Total Grapple weight(kg/lbs)
MD 6.0	270 / 0,35	650 / 25,59	1700 / 66,93	1030 / 40,55	29 / 6519	164 / 362	399 / 880
MD 9.0	400 / 0,52	750 / 29,53	1980 / 77,95	1150 / 45,28	31 / 6969	240 / 529	500 / 1102
MD 12.0	480 / 0,63	800 / 31,50	2100 / 82,68	1250 / 49,21	36 / 8093	328 / 724	673 / 1485
MD 16.0	720 / 0,94	900 / 35,43	2300 / 90,55	1450 / 57,09	46 / 10341	379 / 835	854 / 1883
MD 20.0	1000 / 1,31	1000 / 39,37	2650 / 104,33	1700 / 66,93	55 / 12364	619 / 1365	1319 / 2908
MD 25.0	1200 / 1,57	1100 / 43,31	2750 / 108,27	1750 / 68,90	75 / 16861	739 / 1629	1519 / 3349

Grapple weight - without connection plate

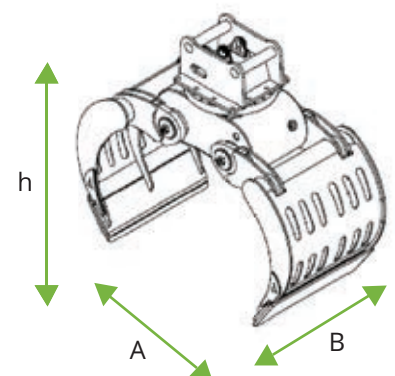

Alligator Grapple

Universal Sorting, Demolition, Rock Handling, Waste sorting, Forest clearing, Root pulling & Timber + Log handling

A-SYNCHRO ARM MOVEMENT

ENVIROMENTALLY FRIENDLY

SELF TOUCH SYSTEM

COMPLETELY PROTECTED MECHANISM AND HYDRAULIC SYSTEM

MORE GRIP POWER

LESS WEIGHT - REDUCED LOAD CENTER - HIGHER CAPACITY

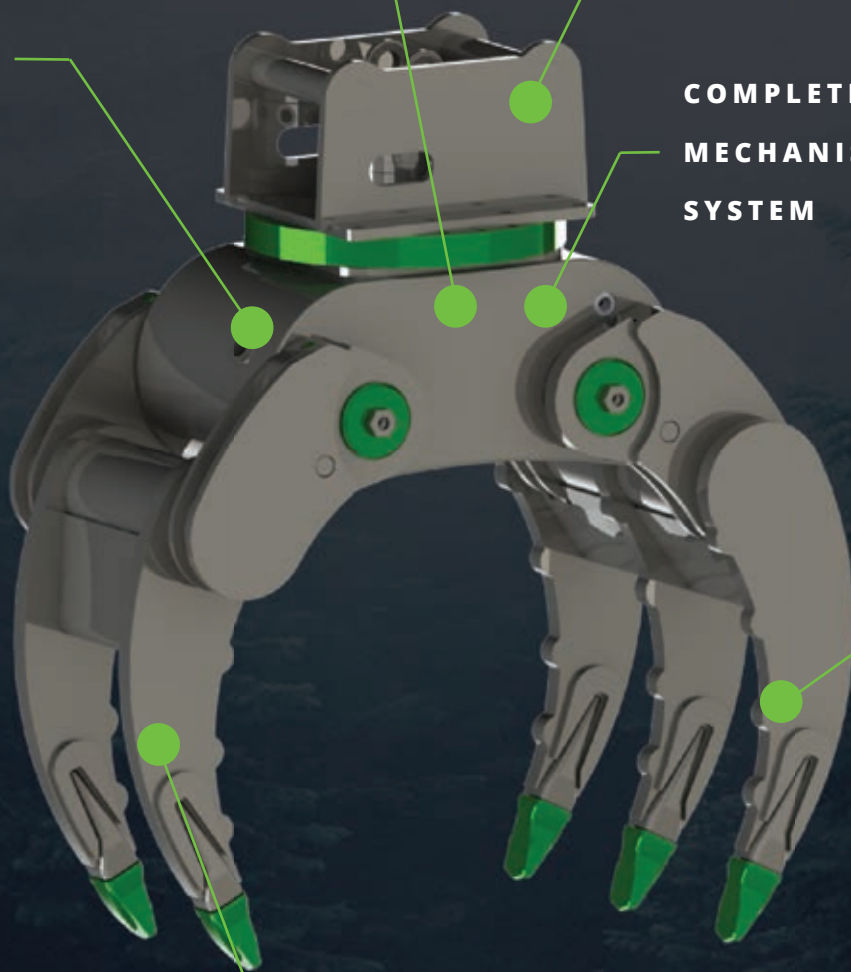

A - Synchro Grip for Root pulling and forest clearing



Timber & Log Manipulation



Grapple with
the **BEST GRIP**

Manipulation



Forest work - clearing & root pulling



Log & Timber Handling

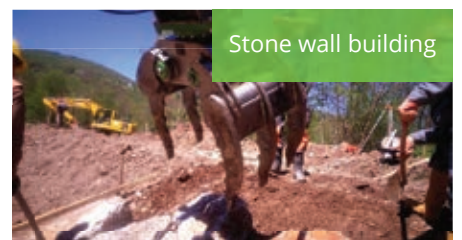

Modularis Multifunctional tool - Alligator Grapple

The new Universal Multifunctional “Alligator” Grapple for Demolition, Sorting & Rock Handling for excavators from 3t / 6600 lbs to 30t / 66000 lbs operating weight

- Extremely robust due to high quality material and new design with totally closed chasis
- Integrated non-return valve guarantees secure retention of loads.
- Including the innovative KGL Swivel motor with 360° endless rotation for precise manipulation
- 30% higher closing force achieved by new Modularis Drive hydraulic system/ 30% less weight due to innovative design
- A – Synchro movement adapts the arm grip to the load shape

Alligator Grapple Universal Sorting, Demolition, Rock Handling, Forest clearing & Root pulling

Type	Min Diameter C (mm/in)	Width B (mm/in)	Max Opening A (mm/in)	Height (mm/in)	Closing force F (kN/lbs)	Arms Weight (kg / lbs)	Total Grapple weight (kg/lbs)
MD 3.0	150 / 5,91	550 / 21,65	1100 / 43,31	800 / 31,50	16 / 3597	95 / 209	261 / 575
MD 6.0	200 / 7,87	650 / 25,59	1300 / 51,18	900 / 35,43	29 / 6519	170 / 375	405 / 893
MD 9.0	300 / 11,81	650 / 25,59	1400 / 55,12	930 / 36,61	31 / 6969	180 / 397	440 / 970
MD 12.0	300 / 11,81	700 / 27,56	1500 / 59,06	1100 / 43,31	36 / 8093	250 / 551	595 / 1312
MD 16.0	300 / 11,81	800 / 31,50	1700 / 66,93	1300 / 51,18	46 / 10341	375 / 827	850 / 1874
MD 20.0	360 / 14,17	950 / 37,40	1900 / 74,80	1500 / 59,06	55 / 12364	600 / 1323	1300 / 2866
MD 25.0	360 / 14,17	950 / 37,40	1900 / 74,80	1500 / 59,06	75 / 16861	665 / 1466	1445 / 3186
MD 30.0	400 / 15,75	1100 / 43,31	2100 / 82,68	1700 / 66,93	85 / 19109	950 / 2094	1900 / 4189

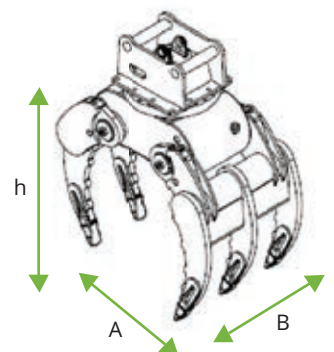

Wood Shear Grapple

Cutting trees, clearing bushes, trimming trees in parks, clearing branches along roads and waterways

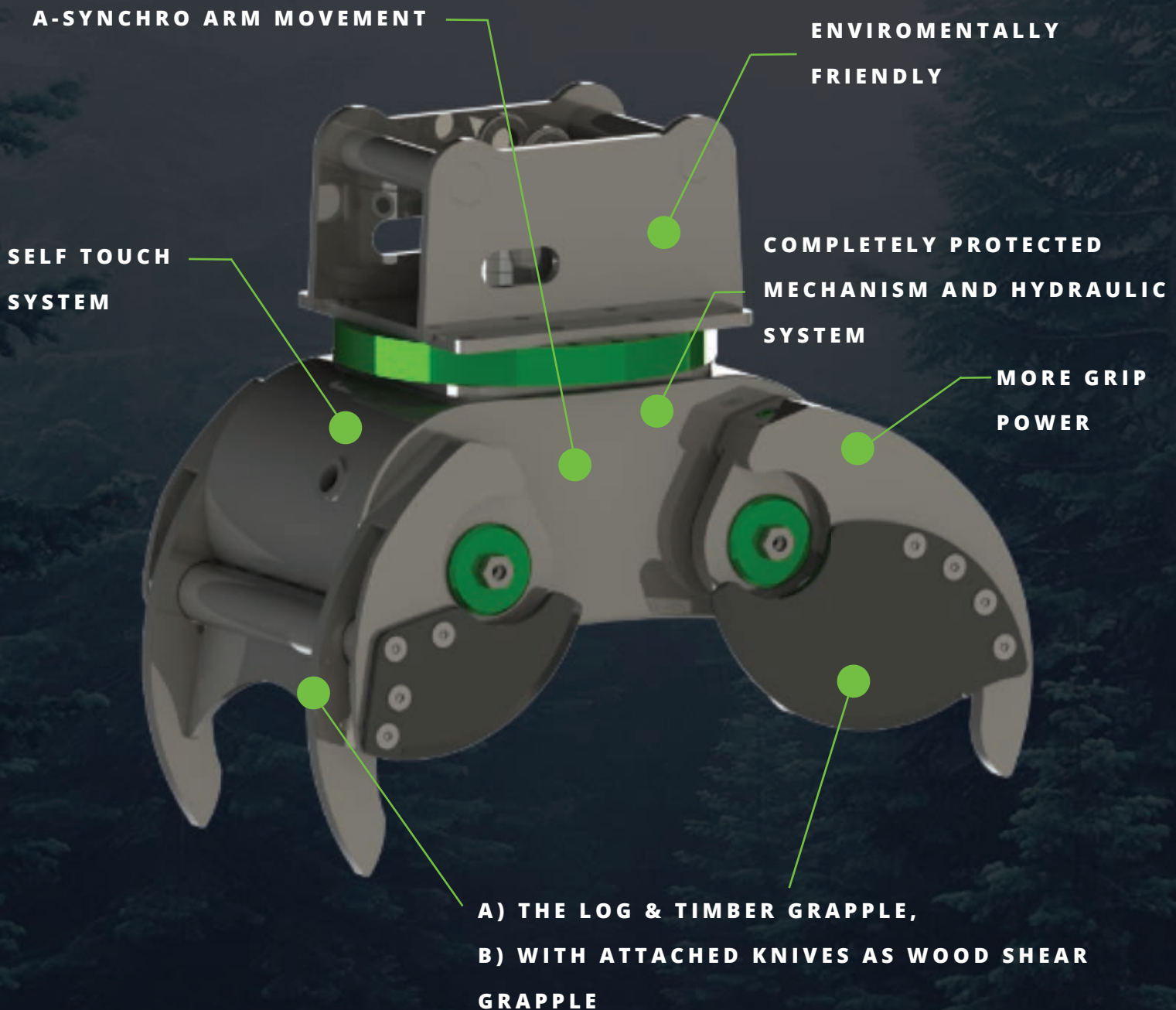



Multifunctional Grapple – as Wood Shear - Model protection & Patent pending

Clearing bushes, trimming trees, clearing branches along roads and waterways



Innovative Grapple design with knives for maximum cutting performance



Trees & Timber cutting and handling



Modularis Multifunctional tool

Wood Shear Grapple

The new Universal Multifunctional “Wood Shear” Grapple for wood cutting and handling for excavators from 5t / 11000 lbs to 25t / 55000 lbs operating weight

- New innovative “Wood Shear ” knife shape - model protection, patent pending
- The new innovative design – Grapple & Wood Shear in one tool
- Extremely robust and easy to maintain, due to use of cutting- edge material 500 HB steel
- Much higher shear power achieved by new knife shape
- The cutting wood can be achieved by A – Synchro arm movement (arms always hold the tree first .. then finish the cutting)

Wood Shear Grapple (Energy wood / Timber / Logs Cutting)

Type	Max Cutting Diameter C (mm/in)	Width B (mm/in)	Max Opening A (mm/in)	Closing force F (kN/lbs)	Arms Weight (kg / lbs)	Total Grapple weight (kg/lbs)
MD 6.0	200 / 7,87	500 / 19,69	630 / 24,80	65 / 14613	80 / 176	315 / 694
MD 9.0	250 / 9,84	550 / 21,65	750 / 29,53	75 / 16861	100 / 220	360 / 794
MD 12.0	300 / 11,81	600 / 23,62	800 / 31,50	85 / 19109	150 / 331	495 / 1091
MD 16.0	350 / 13,78	700 / 27,56	900 / 35,43	102 / 22931	205 / 452	680 / 1499
MD 20.0	400 / 15,75	800 / 31,50	900 / 35,43	123 / 27652	300 / 661	1000 / 2205
MD 25.0	400 / 15,75	800 / 31,50	900 / 35,43	144 / 32372	320 / 705	1100 / 2425

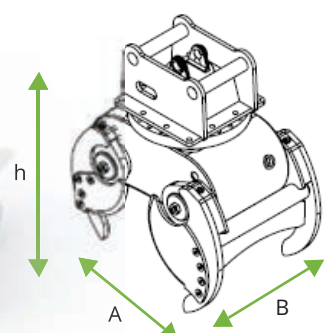

Timber & Wood & Biomass Grapple

Modularis Multifunctional tool – Timber Grapple





Modularis Multifunctional tool - Timber Grapple

The new Universal Multifunctional “Timber” Grapple for handling for excavators from 3t / 6600 lbs to 12t / 26400 lbs operating weight

- Wide range of sorting and manipulation with wood, logs, timbers and biomass material
- The most reliable Grip achieved by A – Synchro arm movement adapts to the load shape.

Timber Grapple (Energy wood / Timber / Logs Handling)

Type	Width B (mm/in)	Max Opening A (mm/in)	Height (mm)	Closing force F (kN/lbs)	Arms Weight (kg / lbs)	Total Grapple weight(kg/lbs)
MD 3.0	300 / 11,81	1100 / 43,31	800	16 / 3597	82 / 181	248 / 547
MD 6.0	400 / 15,75	1250 / 49,21	870	29 / 6519	100 / 220	335 / 739
MD 9.0	500 / 19,69	1500 / 59,06	950	31 / 6969	122 / 269	382 / 842
MD 12.0	500 / 19,69	1500 / 59,06	1100	36 / 8093	145 / 320	490 / 1080



Biomass Grapple

Manipulation of biomass, straw, hay and manure

A-SYNCHRO ARM MOVEMENT

ENVIROMENTALLY FRIENDLY

SELF TOUCH SYSTEM

COMPLETELY PROTECTED MECHANISM AND HYDRAULIC SYSTEM

MORE GRIP POWER

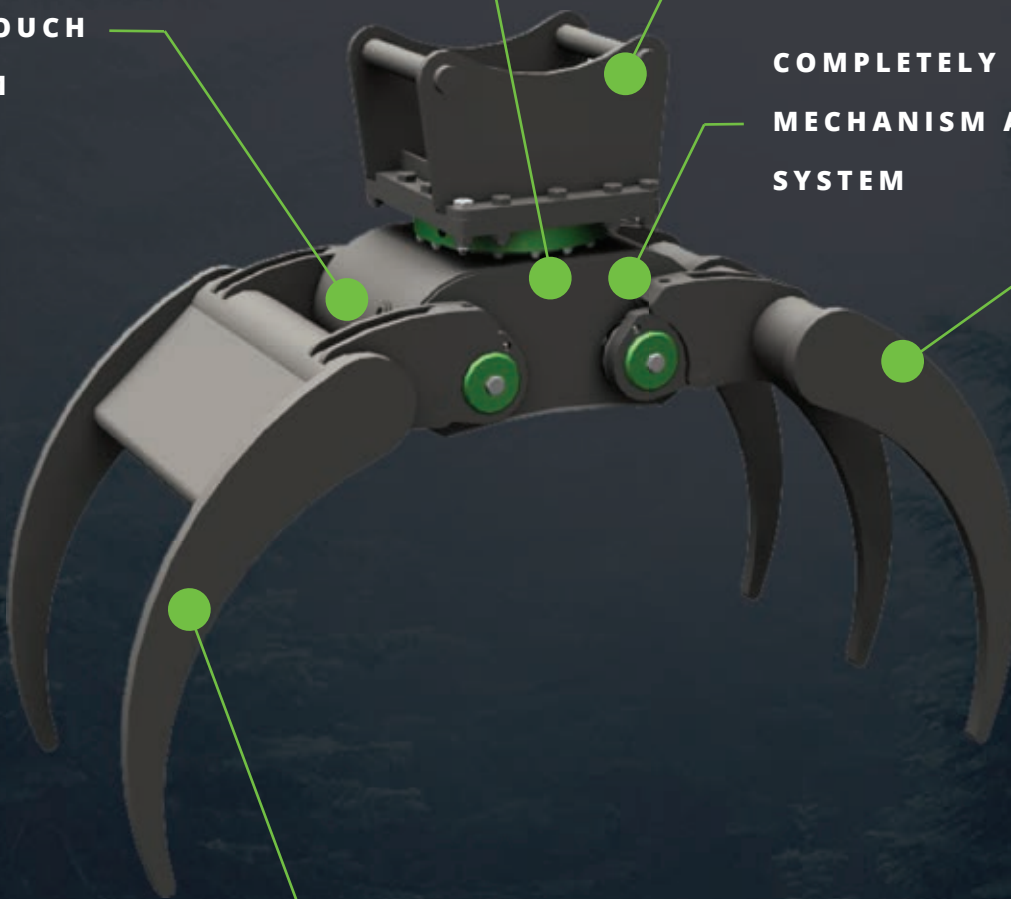

LESS WEIGHT - REDUCED LOAD CENTER - HIGHER CAPACITY

Modularis Multifunctional tool - Biomass Grapple

The new Universal Multifunctional “Biomass” Grapple for biomass manipulation for excavators from 3t / 6600 lbs to 25t / 55000 lbs operating weight

- New improved “Biomass” arm shape
- High volume capacity design for light material handling
- Much higher Grip power achieved by new shape
- The most reliable Grip achieved by A – Synchro arm movement adapts to the load shape

Biomass Grapple

(Energy wood / Waste Sorting / Hay & Straw- Manure loading)

Type	Volume (l/c.y.)	Width B (mm/in)	Max Opening A (mm/in)	Height (mm)	Closing force F (kN/lbs)	Arms Weight (kg / lbs)	Total Grapple weight(kg/lbs)
MD 3.0	270 / 0,35	700 / 27,56	1500 / 59,06	950 / 37,40	16 / 3597	112 / 246	278 / 612
MD 6.0	400 / 0,52	800 / 31,50	1700 / 66,93	1100 / 43,31	29 / 6519	200 / 441	435 / 959
MD 9.0	480 / 0,63	900 / 35,43	1980 / 77,95	1350 / 53,15	31 / 6969	212 / 467	472 / 1040
MD 12.0	720 / 0,94	1000 / 39,37	2100 / 82,68	1450 / 57,09	36 / 8093	294 / 648	639 / 1409
MD 16.0	1000 / 1,31	1100 / 43,31	2300 / 90,55	1640 / 64,57	46 / 10341	441 / 973	916 / 2020
MD 20.0	1200 / 1,57	1200 / 47,24	2650 / 104,33	1850 / 72,83	55 / 12364	706 / 1556	1406 / 3099
MD 25.0	1300/1.70	1300 / 51,18	2700 / 106,30	1900 / 74,80	75 / 16861	782 / 1725	1562 / 3444

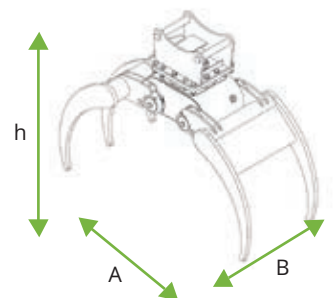

Bulk material Grapple

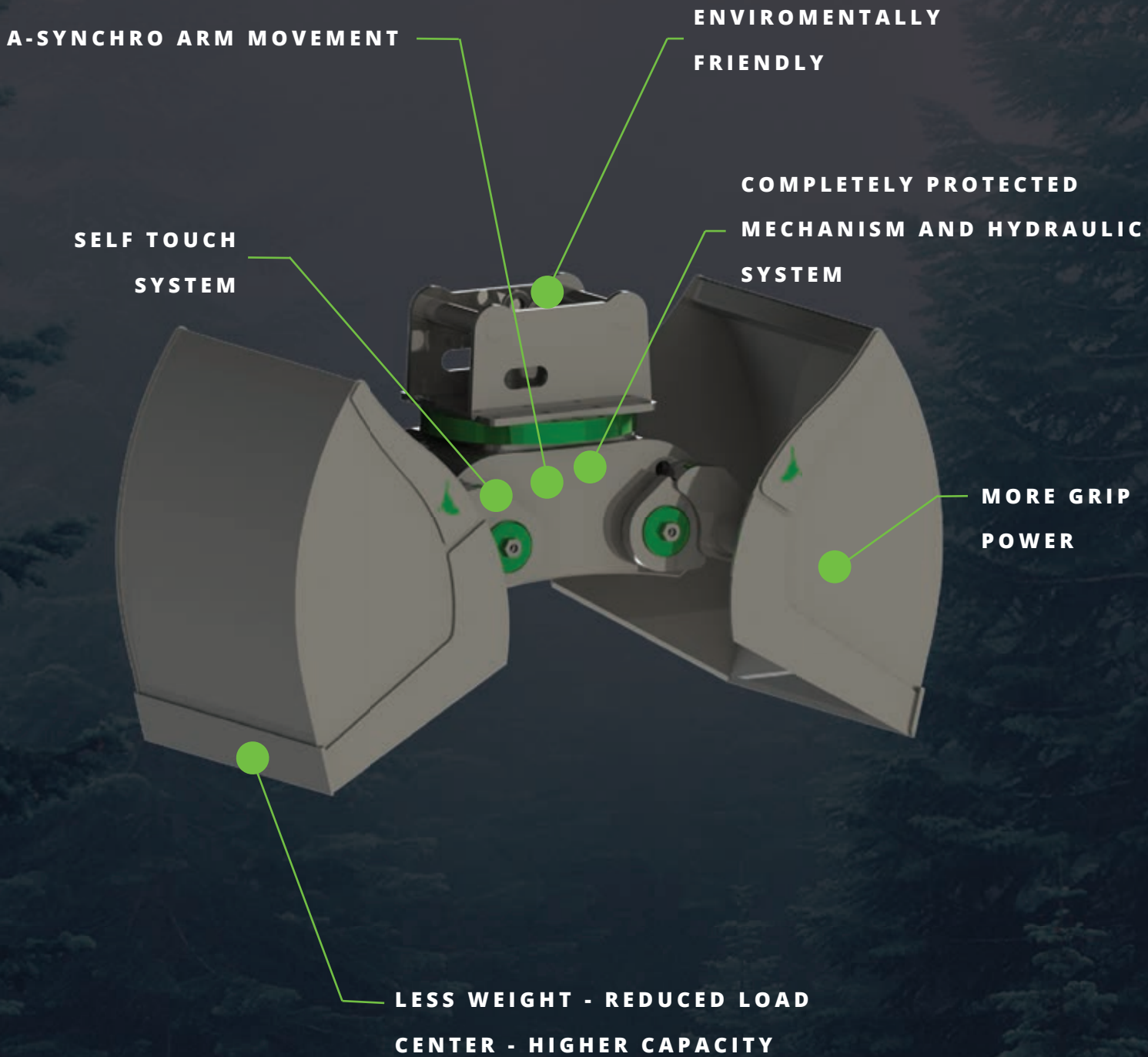

Modularis Multifunctional tool - Bulk material Grapple

The new Universal Multifunctional "Bulk material" Grapple for biomass manipulation for excavators from 3t / 13200 lbs to 30t / 13200 lbs operating weight

- New improved "Biomass" arm shape
- High volume capacity design for light material handling
- Much higher Grip power achieved by new shape
- The most reliable Grip achieved by A - Synchro arm movement adapts to the load shape.

Bulk material Grapple

(Energy wood / Waste Sorting / Hay & Straw- Manuare loading)

Type	Volume (l/c.y.)	Width B (mm/in)	Max Opening A (mm/in)	Height (mm)	Closing force F (kN/lbs)	Arms Weight (kg / lbs)	Total Grapple weight(kg/lbs)
MD 3.0	70 / 0,09	300 / 11,81	1150 / 45,28	0 / 0	16 / 3597	69 / 152	235 / 518
	95 / 0,12	400 / 15,75				81 / 179	247 / 545
	120 / 0,16	500 / 19,69				93 / 205	259 / 571
MD 6.0	160 / 0,21	400 / 15,75	1350 / 53,15	0 / 0	29 / 6519	127 / 280	362 / 798
	200 / 0,26	500 / 19,69				138 / 304	373 / 822
	240 / 0,31	600 / 23,62				149 / 328	384 / 847
	320 / 0,42	800 / 31,50				167 / 368	402 / 886
MD 9.0	300 / 0,39	600 / 23,62	1500 / 59,06	0 / 0	31 / 6969	200 / 441	460 / 1014
	350 / 0,46	700 / 27,56				210 / 463	470 / 1036
	400 / 0,52	800 / 31,50				222 / 489	482 / 1063

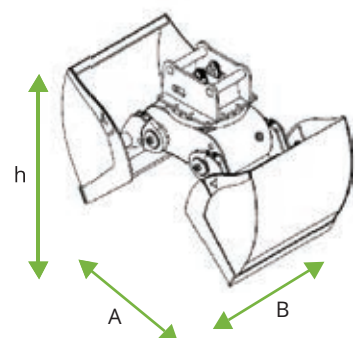
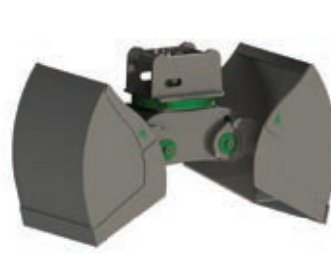

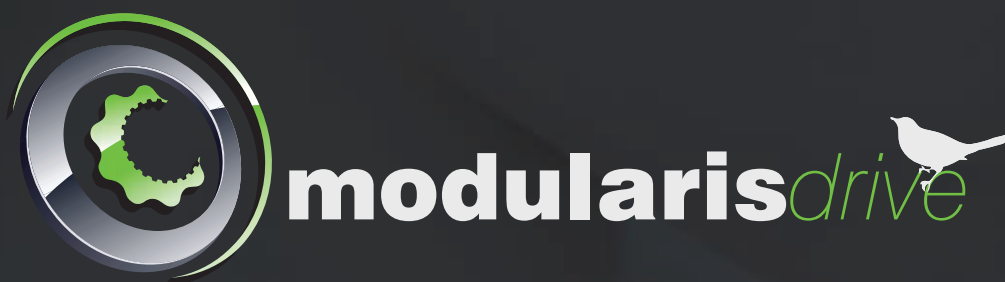

**We come from the heart of the green land
with the environmentally friendly products**

Limiting the possibility of hydraulic oil leaking
into the countryside to the minimum

Modularis teh d.o.o., Ljubljanska c. 11, 1270 Litija

www.modularis-drive.com

T: +386 41 675 156, +386 820 54 280

info@modularis-drive.com